

TSB 04-24-5

A/C/Audio - Defroster/Antenna Grid Diagnosis/Repair

12/13/04 – 13 décembre 2004

**REAR WINDOW DEFROSTER GRID/INTEGRAL
ANTENNA DIAGNOSIS AND REPAIR - TERMINAL TAB
REPAIR**

FORD:

1999-2000 Contour
1999-2002 Escort
1999-2003 Escort ZX2
1999-2005 Crown Victoria, Mustang, Taurus
2000-2005 Focus
2005 Five Hundred, Freestyle
1999-2003 Windstar
1999-2005 Expedition, Explorer
2000-2005 Excursion
2001-2003 Explorer Sport
2001-2005 Escape
2004-2005 F-150, Freestar
2005 Escape Hybrid

LINCOLN:

1999-2002 Continental
1999-2005 Town Car
2000-2005 LS
1999-2005 Navigator
2002-2003 Blackwood
2003-2005 Aviator

MERCURY:

1999 Tracer
1999-2000 Mystique
1999-2005 and Marquis, Sable
2005 Montego
1999-2002 Villager
1999-2005 Mountaineer
2004-2005 Monterey
2005 Mariner

This article supersedes TSB 04-18-9 to update vehicle applications and service procedure.

ISSUE

Some vehicles may exhibit inoperative electric rear window defroster (heated back lite) grid lines, integral antenna concerns causing radio reception issues or terminal tabs pulled from the rear window glass.

ACTION

Follow the diagnostic and repair procedures included in this article to inspect and service rear defroster grid lines, integral antenna concerns or broken terminal tabs.

SERVICE PROCEDURE

Warrantable/Non Warrantable repairs

Warrantable grid line repairs typically can be identified by one inoperative grid line with a small discoloration at the area of concern, approximately the size of a pinhead. Grid line(s) that are scratched or have the silver material removed are not warrantable and should be addressed with the customer. Replacement of backglass for grid line or bus bar tarnishing is not a warrantable repair. Tarnishing of the silver lines or bus bars is a normal condition. Please refer to the Heated Back Lite Damageability Job Aid for additional information and examples of defects and damage.

NOTE THE GRID LINE MATERIAL IS NOT EMBEDDED INTO THE GLASS BUT IS BAKED TO THE GLASS SURFACE AND CONSEQUENTLY CAN BE SCRAPED OFF. INOPERATIVE LINES MAY APPEAR TO THE EYE TO BE UNDAMAGED DUE TO RESIDUE REMAINING ON THE GLASS AND WILL REQUIRE DIAGNOSIS WITH A VOLTMETER OR 12V TEST LAMP AS EXPLAINED IN THIS ARTICLE.

Examples Of Non-Warrantable Grid Line Damage

- Ice scraper damage to grid lines
- Animal scratches on grid lines
- Window tint film/removal of the film which damages grid lines
- Stickers placed over grids which upon removal, removes the grid line material
- License plate (steel type placed against the inside of back glass) which rubs on the grid line causing damage
- Temporary license plate (paper stuck on to the inside of the back glass) which upon removal removes grid line material
- Cargo or lumber rubbing against the glass which removes grid line material
- Cellular phone antenna installation/removal which damages grid line material

NOTE AN UNDAMAGED GRIDLINE WILL HAVE SMALL RIDGES THAT PROJECT ABOVE THE SURFACE OF THE GLASS AND CAN EASILY BE FELT WHEN RUNNING A FINGERNAIL ACROSS THEM.

GRIDLINES THAT HAVE BEEN "RAZOR BLADED" WILL FEEL SMOOTH WHEN A FINGERNAIL IS DRAGGED ACROSS THE AFFECTED AREA. THERE MAY BE SOME RESIDUE LEFT ON THE GLASS THAT APPEARS TO BE GRID MATERIAL BUT A CHECK WITH A VOLTMETER OR 12V TEST LAMP, AS EXPLAINED IN THIS ARTICLE, WILL CONFIRM AN OPEN CIRCUIT.

GRID LINE INOPERATIVE - DIAGNOSTICS

1. Reference Workshop Manual Section 501-11 and the Wiring Diagram Section 56 to verify power and ground to the back-glass.
2. Connect a test lamp or DVOM to a good body ground.
3. Turn the ignition key to the run position and depress and release the rear defroster button to turn the system on. THE GRID IS ENERGIZED FOR APPROXIMATELY 10 MINUTES EACH TIME THE DEFROSTER BUTTON IS PRESSED.
4. Starting from the top grid line at the center of the back-glass, touch the test lamp or DVOM + lead to each grid line. (Use caution not to damage grid lines). The DVOM should read approximately 1/2 of the battery voltage on each line at the center of the back-glass. If using a test light, the bulb should be approximately the same brightness on each line from top to bottom. If the

DVOM or light indicates a high voltage or no voltage on any grid line, move along the concern grid line with the + test lead or test lamp until the voltage changes suddenly. This is the area of concern, use chalk to mark the area of concern and mark the outside of the glass at that same area.

5. Repair per the Grid Line Repair Procedure.

GRID LINE REPAIR PROCEDURE

NOTE LONG GAPS ARE ALMOST ALWAYS DUE TO DAMAGE AND ARE NOT WARRANTABLE, HOWEVER THEY CAN BE REPAIRED. THE LONGER THE GAP THE MORE IMPORTANT IT IS TO APPLY A MINIMUM SIX (6) COATS OF CONDUCTIVE REPAIR MATERIAL WITH THE FIVE (5) MINUTE DRY TIME BETWEEN EACH COAT. APPLYING LESS COATS OR NOT ALLOWING DRY TIME BETWEEN COATS WILL PRODUCE REPAIRED RESISTANCE THAT IS GREATER THAN OEM RESISTANCE, RESULTING IN POOR DEFROST PERFORMANCE AND EXCESSIVE LOCALIZED HEATING. REPAIRED LONG GAPS ARE GENERALLY NOT VISUALLY PLEASING UNLESS EXTREME CARE IS TAKEN WHEN TAPING AFFECTED GRID LINE AREAS.

NOTE IF THE BROWN COLOR UNDER THE GRID LINE IS DAMAGED OR MISSING (THIS IS VERY RARE), IT WILL BE NECESSARY TO APPLY BROWN ACRYLIC LACQUER TOUCH-UP PAINT FOR COLOR MATCH. THIS PAINT MUST MEET SPECIFICATION ESR-M2P100-C AND SHOULD BE APPLIED TO THE GLASS PRIOR TO APPLYING THE REAR WINDOW DEFROSTER REPAIR COMPOUND.

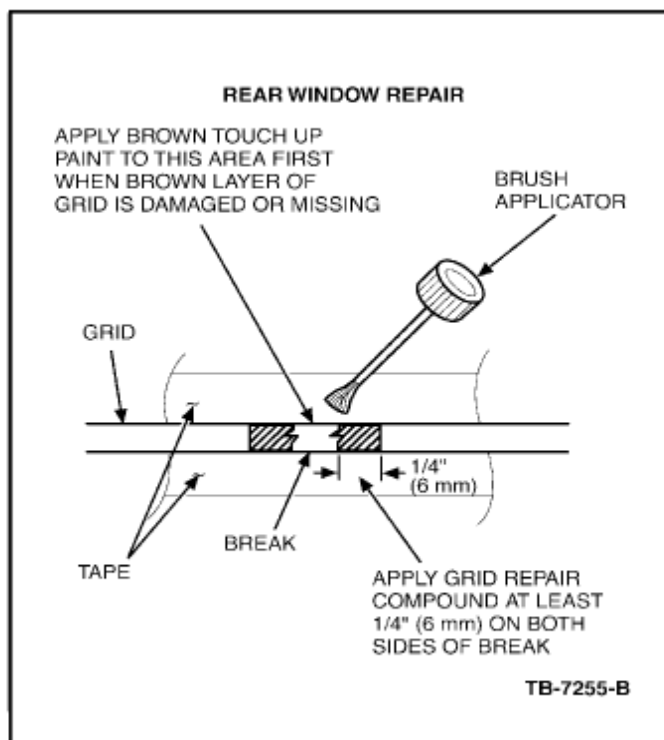

Figure 1

Service inoperative grid lines on rear window glass using Motorcraft Defroster Repair PM-11 or equivalent meeting Ford specification ESB-M4J58-A as follows:

Surface Preparation

1. Bring vehicle inside and warm it to 60°F (16°C) or above.
2. Do not use scrapers, sharp instruments, or abrasive window cleaners on the interior surface of the rear window glass as this may cause damage to the grid lines. Clean the entire grid line service area

with Ultra Clear Spray Glass Cleaner ZC-23 or equivalent meeting Ford specification ESR-M14P5-A to remove all dirt, wax, grease, oil or other foreign matter. It is important that the repair area be clean and dry.

NOTE THE REPAIR AREA HOWEVER SHOULD BE CLEANED WITH STEEL WOOL OR AN ABRASIVE PAD SUCH AS SCOTCHBRITE TO REMOVE GRIME.

Mixing

The bottle of Rear Window Defroster Repair compound and touch-up paint (if needed) must be at room temperature. Shake the bottle for at least one (1) minute for thorough mixing. Shake frequently during use.

Application

1. Mark location of open grid on the outside of the back window glass (performed in diagnostics). Place protective covering over the package tray as necessary.
2. Using "fine line tape", mask off the area directly above and below open grid line (Figure 1). It is best to extend the tape 26 mm (1") beyond the concern area in both directions. The open should be at the center of the mask and tape gap must be no wider than the existing grid line. Other types of tape may be used but end results of the repair may not appear as visually acceptable due to ease of application and tape edge finish.
3. If the brown layer of the grid is not broken or missing, apply only the silver grid repair compound to the open grid line. Apply the correct coating in several smooth continuous strokes (allowing five (5) minutes drying time between coats) across the open grid line area using the brush applicator in the cap. Extend the service coating at least 6 mm (.25") on both sides of the open grid line area. Apply a minimum of six (6) coats of the grid repair compound.
4. If both brown and silver layers of the grid are broken or missing, apply a coating of brown lacquer touch-up paint across the open line area first. Take care to paint only the area missing the color. Two (2) coats may be necessary to obtain the proper color. Allow the touch-up paint to dry at least five (5) minutes between coats. Apply six (6) coats of grid repair compound.

NOTE THE INTERIOR SIDE OF THE GRID LINES ARE NOT PAINTED, BUT DUE TO THE SILVER TARNISHING WILL TEND TO CHANGE THE GRID TO A GOLD OR BROWN COLOR. THE REPAIRED AREA WILL BE BRIGHT SILVER AND WILL ALSO TARNISH OVER TIME TO MATCH THE REST OF THE GRID.

5. After five (5) minutes of dry time of the final coat of grid repair compound, remove the tape, step outside and inspect the repaired area. If the repair compound is visible above or below the grid, the excess can be removed. This may be done by placing a single-edge razor blade on the back window glass parallel to grid and scrape gently toward grid. A wider/thicker line will perform better but may not be cosmetically appealing.

CAUTION BE CAREFUL NOT TO DAMAGE GRID LINE WITH RAZOR BLADE. VERIFY ALL OF THE GRID LINES FUNCTION PROPERLY WHEN FINISHED.

Curing

The service coating will air-dry in approximately one (1) minute and the system can be energized after five minutes. Maximum hardness and adhesion occur after approximately 24 hours.

SOLDER METHOD OF LEAD TERMINAL

NOTE THE REAR WINDOW MUST BE AT A MINIMUM OF 60°F (16°C) BEFORE A REPAIR IS MADE.

PLACE PROTECTIVE COVERING OVER THE PACKAGE TRAY AS NECESSARY.

The new terminal will cover the original terminal location, but must be placed so that the new terminal conductive areas will be placed on a good conductive base. This area should be cleaned with steel wool or an abrasive pad to remove grime from the buss-bar. The area should then be cleaned with Ultra Clear Spray Glass Cleaner, ZC-23, or equivalent meeting Ford specification ESR-M14P5-A to remove all dirt, wax, grease, oil or other foreign matter. It is important that the repair area be clean and dry and appear metallic. Depending on the buss-bar condition, rigorous polishing with steel wool may be required. Please note that the entire buss-bar may be cleaned to improve appearance.

CAUTION DO NOT USE ANY TYPE OF FLAME TORCH OR FLAME HEATED SOLDERING GUN FOR THIS PROCEDURE. TESTING INDICATED INADEQUATE HEAT GENERATION AT THE TIP AND THE EXHAUST HEAT CAN CAUSE DAMAGE TO PLASTIC TRIM PARTS IN THE AREA. USE ONLY AN ELECTRIC SOLDERING GUN WITH 100 WATTS OR MORE OF POWER.

BEFORE USING THE SOLDERING GUN, BE SURE TO MELT A SMALL AMOUNT OF ROSIN CORE SOLDER TO THE TIP. THE SOLDER WILL ASSIST IN ACHIEVING BETTER HEAT TRANSFER FROM THE SOLDERING GUN TIP TO THE NEW TERMINAL.

The new terminal has pre-applied solder, flux and temperature sensitive paint. The paint provides a visual indication when the terminal has reached the proper temperature to melt the solder on the terminal. When the proper temperature is achieved the temperature paint will liquefy and change color.

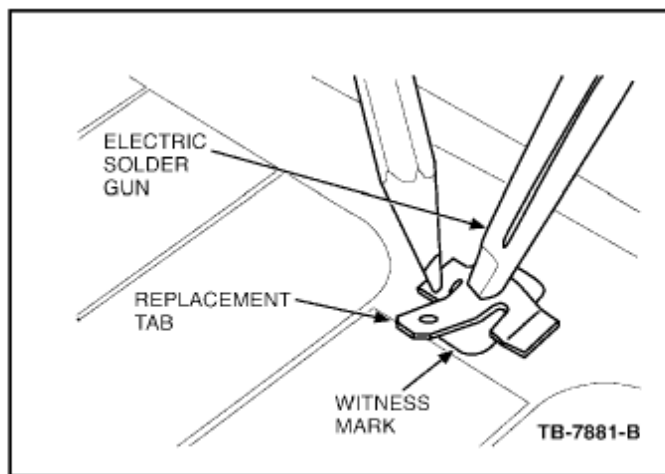

Figure 2

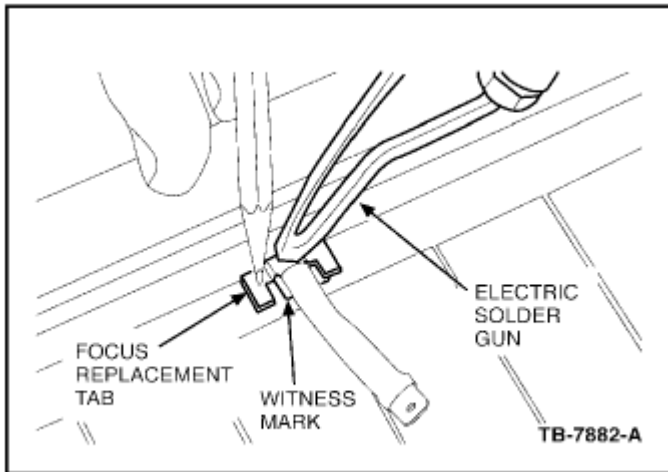

Figure 3

Use terminal type A (Figure 2) for all tab locations except on the Focus vehicle line. For the Focus, use type B (Figure 3).

NOTE DEPENDING ON THE ORIGINAL TERMINAL LOCATION, AND WHETHER THE TERMINAL IS COVERED BY PILLAR TRIM, WILL DETERMINE WHERE TO LOCATE THE NEW TERMINAL. SOME GRID LINE BUSS-BARS MAY ONLY ALLOW THE PLACEMENT OF THE TERMINAL ABOVE OR BELOW THE ORIGINAL TAB LOCATION DUE TO SPACE LIMITATIONS, BUT FOR MOST VEHICLE APPLICATIONS THE REPLACEMENT TAB LOCATION WILL COVER THE ORIGINAL TAB LOCATION BUT STILL ALLOW THE REPLACEMENT TAB TO ATTACH TO THE BUSS-BAR ON GOOD CONDUCTIVE MATERIAL.

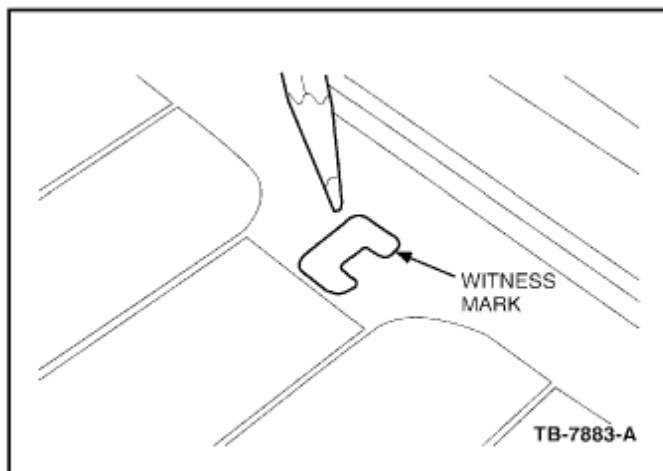

Figure 4

1. Place the replacement terminal over the original tab location making sure the conductive areas of the terminal will be on a good conductive area. Do not place the terminal tab foot on the original location which does not have conductive material (figure 4).
2. Hold the terminal in place with an item such as regular lead pencil at a 90 degree angle from the terminal. (Terminal type B can be held in place with tape.) (Holding at other than a 90 degree angle may allow the terminal to slip when the solder liquefies).
3. Place the soldering gun tip on the top of the terminal but not on the painted areas of the tab. Energize the soldering gun and watch for the painted area of the terminal to liquefy and change color. The paint should liquefy in approximately 25-45 seconds after heating. As soon as the paint

color completely changes on either side of the terminal, de-energize the soldering gun and continue to hold the terminal in place with the soldering gun and pencil for an additional thirty (30) seconds.

4. Remove the soldering gun and pencil from the terminal. The terminal should be allowed to cool for another two (2) minutes before the wiring lead is attached to the terminal.

5. Attach the electrical lead connection to this terminal, turn on the rear defroster, and verify operation.

PART NUMBER	PART NAME
PM-11	Motorcraft Defroster Repair
ZC-23	Ultra Clear Spray Glass Cleaner
4F1Z-14421-AA	Terminal Kit - Backglass

Parts Block

WARRANTY STATUS: Eligible Under Provisions Of New Vehicle Limited Warranty Coverage

OPERATION	DESCRIPTION	TIME
042405A	Repair Grid Lines (Includes Time To Diagnose And Recheck)	0.7 Hr.
042405B	Replace Terminal (Includes Time To Diagnose And Recheck)	0.4 Hr.
042405C	Repair Grid Lines And Replace Terminal (Includes Time To Diagnose And Recheck)	0.8 Hr.

DEALER CODING

BASIC PART NO.	CONDITION CODE
7042006	28

NOTE: The information in Technical Service Bulletins is intended for use by trained, professional technicians with the knowledge, tools, and equipment to do the job properly and safely. It informs these technicians of conditions that may occur on some vehicles, or provides information that could assist in proper vehicle service. The procedures should not be performed by "do-it-yourselfers". Do not assume that a condition described affects your car or truck. Contact a Ford, Lincoln, or Mercury dealership to determine whether the Bulletin applies to your vehicle.